

## reflecta 105P TV Sehpa



60-105"  
152-267 cm

max.  
100 kg  
TV

max.  
25 kg  
DVD

VESA

400x400 600x400  
800x400 800x600  
1000x600

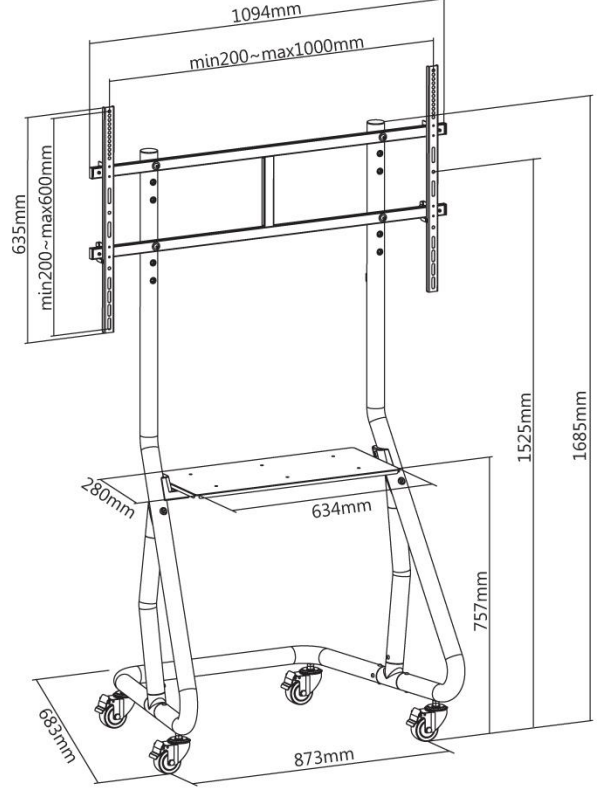

### Ürün Bilgisi

- Üniversal TV Sehpa
- Maksimum taşıma kapasitesi (TV): 100 kg
- Maks. taşıma kapasitesi (raf): 25 kg
- 60-105" (152-267 cm)
- Vesa: 400x400, 600x400, 800x400, 800x600, 1000x600
- Yüksekliği ayarlanabilir (1425 mm / 1475 mm / 1525 mm)
- Hırsızlığa karşı koruma
- Kablo yönetimi
- Malzeme: Toz boyalı çelik, plastik, alüminyum
- Boyutlar: 1094x683x1685mm

Kod: 23193  
EAN: 4005039231933

Özellikler, önceden haber verilmeksizin değiştirilebilir

**reflecta gmbh**  
Merkurstrasse 8  
D 72184 Eutingen  
Phone: +49 (0) 7457 9465-60  
Fax: +49 (0) 7457 9465-72  
e-mail: [mail@reflecta.de](mailto:mail@reflecta.de)  
http: [www.reflecta.de](http://www.reflecta.de)